

Troubleshooting

Symptom

- LCD Display is blank after the 2 minute warm-up period (8002 and 8008 models).

Remedy

- Remove the sensor from the wiring plate and check the voltage on pins 1 and 2 of the 2-pin terminal block. The voltage should be: 18-30 VAC RMS or 18-42 VDC.
- Ensure that the sensor pins that connect to the 2-pin terminal block are not broken, bent, or damaged.
- If the LCD display is still blank after replacing the sensor on the mounting plate, call Telaire or your distributor/dealer for a return authorization number.

Symptom

- Green light is not illuminated (8001 and 8008 models) after the two minute warm-up period.

Remedy

- Remove the sensor from the wiring plate and check the voltage on pins 1 and 2 of the 2-pin terminal block. The voltage should be: 18-30 VAC RMS or 18-42 VDC.
- Ensure that the two pins on the sensor that connect to the 2-pin terminal block are not broken, bent, or damaged.
- If the green light is still not illuminated after replacing the sensor on the mounting plate, try verifying the sensor operation using the UIP8000 computer interface or checking the output signal on the building automation system.
- If there is not an output signal, call Telaire or your distributor/dealer for a return authorization number.

Symptom

- Suspect the sensor is out of calibration.

Remedy

- Compare the sensor reading to a Telaire 7001 hand-held CO₂ monitor, or
- Take another sensor from the building and replace the suspect sensor to see if the readings are similar, or
- Connect the sensor outdoors (if possible). The readings should be between 350 and 450 ppm, or
- Connect the sensor to nitrogen gas from a Model 2075 calibration kit. The reading should be close to zero.
- If the sensor proves to be out of calibration, calibrate the sensor according to the instructions included in your calibration kit or return the sensor to Telaire for factory calibration (call for a return authorization number).

Symptom

- Relay does not actuate at the proper setpoint.

Remedy

- Using the LCD menu or the UIP8000 computer interface, verify that the relay setpoint is correct.
- Return the sensor to normal operating mode, and breathe into the sensor to raise the ppm value above the relay setpoint.
- If the relay does not actuate at the proper setpoint, call Telaire or your distributor/dealer for a Return Authorization (RA) number.

Warranty

Telaire seeks to present reliable information concerning the composition, properties and use of its products, however; (1) All advice concerning selection and use of any product is provided at no charge and with no warranty. (2) No warranty is made hereby. Products described herein are warranted to conform to Telaire specifications only at the time of sale. All sales are subject to Telaire standard terms and conditions, which are reproduced on the reverse side of each invoice. All warranties of merchantability and fitness of purpose are disclaimed and remedy for any breach of warranty is limited to replacement of the defective product. (3) Telaire assumes no responsibility for any patent liability arising from the use of any product in a process, manner or formula not designed by Telaire.

©Copyright 1999-2004

Specifications

Method

Single Beam Absorption Infrared™
Diffusion sample method (8001, 8001B, 8002, 8002B)
Flow-Through sample method (70-120 ml/min) (8007, 8008)

Performance

Measurement Range

0-2000 ppm factory default
Adjustable to 10,000 ppm with UIP software kit

Accuracy

±100 ppm or 7% whichever is greater

Elevation (Pressure) Correction

Add 0.13% of reading per mm Hg decrease from
760 mm Hg (On-board correction, user set with UIP software)

Response Time 0-90%

<1 minute

Warm-Up Time @ 25°C

<2 minutes

Operating Conditions

15 – 32°C (60-90°F)
0 – 95% RH, non-condensing

Storage Temperature

-40 – 70°C

Agency Certification

FCC Part 15 Class B, CE, California Energy Commission

Input/Output

Power

18-30 VAC RMS, 50/60 Hz – half-wave rectified
18-42 VDC polarity protected
1.75 VA maximum average power
2.75 VA peak power

Analog Output (Simultaneous)

0-10 VDC (100 Ohms output impedance)
4-20 mA (RLmax = 500 Ohms)

Relay Output

Normally Open and Normally Closed (wire either way), gold bifurcated, 2A max. @ 24VAC. Adjustable setpoint, factory set at 1000 ppm, 50 ppm hysteresis

Wiring

18-28 AWG stranded copper wire only. 2 wires each for power, analog output, relay

Digital I/O

RS-232 interface for use with optional PC software and cable in UIP kit 2072

Warranty/Other

Warranty

18 months parts and labor

This product is covered by one or more of the following patents:

5,650,624 / 5,721,430 / 5,444,249 / 5,747,808 / 5,834,777 / 5,163,332 / 5,340,986 / 5,502,308 / 6,344,798 / 6,023,069 / 5,370,114 / 5,601,079 / 5,691,704 / 5,767,776 / 5,966,077 / 6,107,925 / 5,798,700 / 5,945,924 / 5,592,147 / 6,255,653 / 6,250,133 / 6,285,290

Installing The Sensor

NOTICE!

Use of cellular telephones or radio transceivers within two (2) feet of the sensor during calibration process could cause sensor interference, calibration errors and affect sensor accuracy. Please refrain from using these devices during sensor calibration.

Basic Installation of the Mounting Plate and Sensor

- Prepare for installation by using the mounting holes configured for US or European junction boxes.
- Use the mounting plate as a template to mark mounting holes.
- Secure the Mounting Plate to the wall or junction box and make necessary wire connections.
- Mount the Controller on the base by aligning the top clips and then securing to the bottom clips. A "snap" sound will indicate that the sensor is secure. The sensor will now have power. A 2 minute warm-up will take place. After 2 minutes, the sensor will stabilize and display the "Normal Mode" (current CO₂ readings).
- At this point one of nine preset programs or one custom channel can be selected for operation. Refer to "Configuring the Sensor."
- Finish installation by sliding the cover over the menu keys and secure with the supplied screw.

2-3.

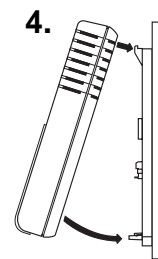
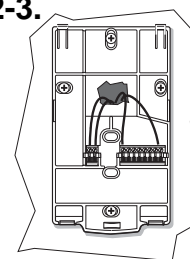

5-6.

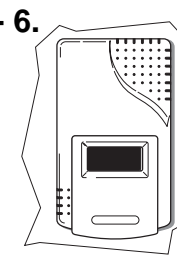

Sensing Duct CO₂ Concentrations

Duct-Mounting the 8001B and 8002B

The 8001B and 8002B have the UL94-V5 rated black case and are specifically designed for mounting inside the return air ductwork. When mounting these products inside the ductwork, seal the hole around the wires and leave the duct insulation in place to prevent condensation which may damage the sensor.

Pitot Tube Installation for the 8007 and 8008

Install the mounting bracket then install the pitot tube assembly as follows:

Note: The length of the Tygon® tubing is three feet. In order to maintain optimum accuracy, the tubing should not be lengthened. If the sensor is mounted closer than three feet, the excess tubing should be shortened to avoid interference with mechanical or moving devices.

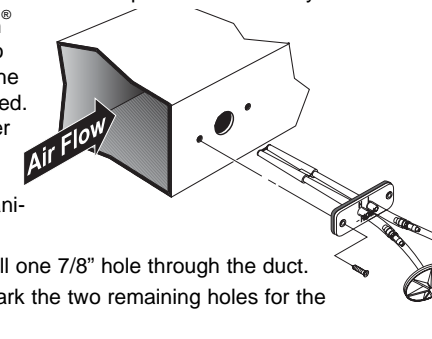

- To mount the pitot tube, drill one 7/8" hole through the duct.
- Insert the pitot tube and mark the two remaining holes for the mounting screws.
- Punch or drill the two marked holes.
- Note the direction of airflow in the duct.
- Note the marking on the pitot tube flange and insert so that it is properly aligned with the airflow.
- To ensure an air tight seal, make sure the mounting surface of the duct is clear of dirt or obstructions. Then, attach the pitot tube to the duct with sheet metal screws or rivets.
- On top of the sensor, unscrew the protective caps from the tube connectors.
- Check the length of the tubing before attaching to the sensor. The tubing should connect without stretching or pulling. If the length is long enough to create a loop or bind in the tubing, it should be shortened.
- To shorten the tubing, remove the connectors that attach to the sensor and cut the tubing to length.
- Replace the tubing connectors by using a twisting or screwing motion. Verify the connection is secure.

Note: If the tubing length has been shortened, be sure the in-line filter is replaced on the pitot tube connector marked with an "H".

- Complete the installation by screwing the tube connectors to the input ports on the sensor. The tubing connectors can be attached to either input port. It will not affect the performance of the sensor.

Ventostat® 8000 Series

Commercial Product - Operation/Installation Manual

Carbon Dioxide (CO₂) Sensors and Controllers

Covers the following Models: 8001 / 8001B / 8002 / 8002B / 8007 / 8008



TELAIRE®

6860 Cortona Drive, Suite B - Goleta, California, 93117
P- 805-685-4000 F- 805-685-0015

62659-006 09/08/2004

Accessory Enclosures

Model 1508 Duct Mount Enclosure (Aspiration Box)

Any 8000 product can be installed inside a Model 1508 Duct Mount Enclosure.

Model 1551 Outside Air Measurement Enclosure

This NEMA-3R weatherproof for measuring outside air CO₂ concentrations. Includes heat stabilizers.

Model 1505 Harsh Environment Enclosure

For extreme environments where the sensor might be subjected to condensation or water spray such as those found in greenhouses or breweries- NEMA-3R rated.

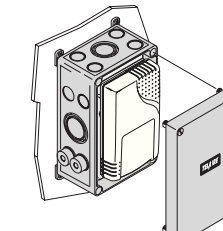
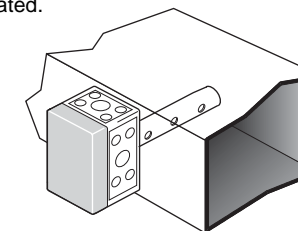

Typical Wiring Diagrams

AC Power 3-Wire System

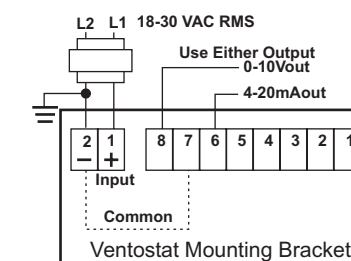

Isolated AC Power 4-Wire System

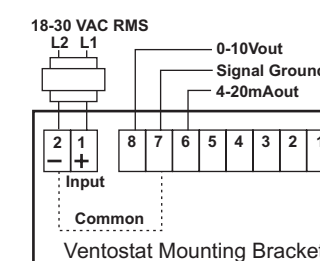

Typical Wiring Diagrams (Continued)

Using the Relay Contacts

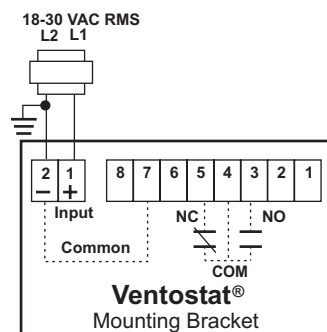

Lennox L-Series

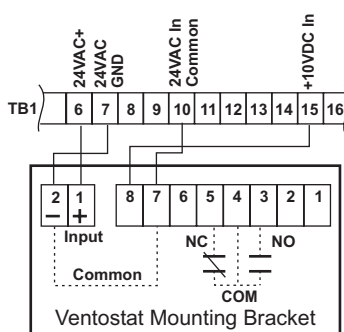

Lennox L-Series w/ Johnson Controls Metasys UNT or Facilitator FA-UNT

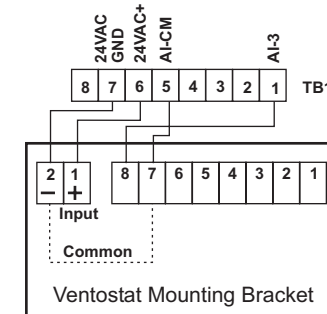

8-Pin and 2-Pin Terminal Block Pin Designations on the Ventostat Mounting Bracket

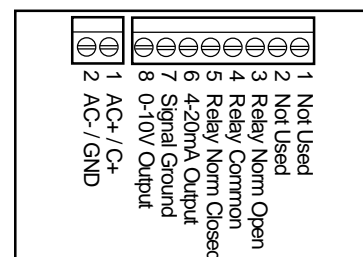

Honeywell M7415 Damper Actuator with W7459 Logic Module

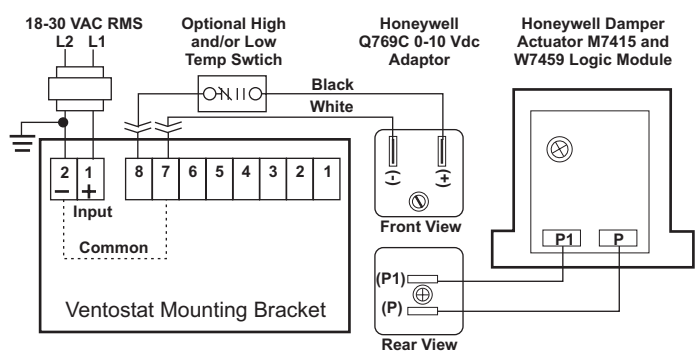

Set minimum position potentiometer to twice the design load. For example, if the space is designed for 30 people at 15 cfm/person, adjust the minimum position potentiometer at the economizer logic to 900 cfm. This will allow the economizer to introduce 450 cfm (1000 ppm CO2 level) at the design load. The CO2 sensor should use "STDSET#1."

NOTE: 24V- Do not use HVAC unit transformer. Provide 24V by non-grounding transformer.

Johnson Controls M100E Economizer Actuator with R81EAA-2 Interface Board

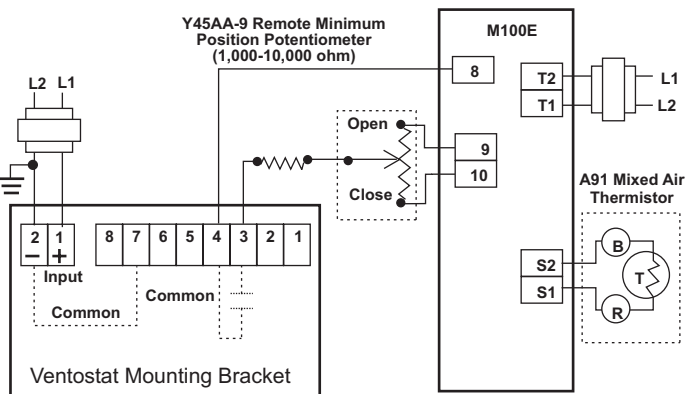

Configuring the Sensor

Adjustable Sensor Settings

The Telaire 8000 series includes features which are user adjustable. These adjustments can be made using the keypad on display units or by the PC based UIP program that communicates to the sensor via a custom RS232 interface cable.

Factory Settings

The default settings are the typical settings used by a building control system. If the installation requires changes to the sensor, the user can customize certain characteristics of the sensor. For example, non-factory settings may be applicable when the sensor is being connected to equipment that has a fixed input range (e.g actuators used with economizer systems).

Outlined below are the adjustable parameters of the sensor and the factory setting. In addition to these adjustable features, the programming interface allows for a fast and simple adjustment of sensor calibration.

Sensor Programming Features

Adjustment	Range	Factory Setting
Altitude Above Sea Level	0-10,000 Ft	0 Ft
ABC Logic™	On/Off	On
Select Standard Setting	1 to 9	1
Customize Setting		
PPM Range	0-10,000	0-2,000
Output Range	4-20mA / 0-10V	4-20mA / 0-10V
Proportional/Exponential Output	Select One	Proportional
Relay Setpoint	0-10,000 PPM	1000 PPM
Relay Hysteresis	0-10,000 PPM	50 PPM

8000 Series Adjustment Parameters and Factory Settings

All Telaire 8000 series products are calibrated at sea level. As altitude increases, the accuracy of this sensor, as all gas sensors, introduces an error of approximately -3% of the reading per 1,000 ft of elevation. Users that are in elevations significantly higher than sea level such as Denver, Colorado should consider adjusting the altitude to have the most accurate reading. The altitude setting can be adjusted on the unit in 500 ft increments.

ABC Logic™ Self Calibration System

All Telaire 8000 series sensors are factory set with the ABC Logic™ (Automatic Background Calibration) self calibration feature ON. This feature allows the sensor to continually recalibrate itself when the indoor concentrations drop to outside levels while the building is unoccupied. Generally a building must be regularly unoccupied for 4 hours or more for this self-calibration system to operate properly. Under these conditions, ABC Logic™ should maintain sensor calibration over the lifetime of the sensor. The ABC Logic™ should be turned OFF where a building is continuously occupied 24 hours per day, or where there could be significant sources of non-occupant related CO2 such as greenhouses, breweries and other industrial and food processing applications.

Pre-Programmed Settings

In addition to the factory setting for the 8000 series sensors, there are 9 standard settings that can easily be selected using the keypad (display units only) or the PC based UIP Program. The chart below describes each of the settings. The definitions for some of the terms used in the chart are described in more detail as part of the custom settings section to follow.

Settings 1, 2 and 3 are applicable for automated or computerized building control systems.

Settings 4 to 7 are specifically designed for operation with economizer controls and actuators where a 0-10 VDC signal will provide 0-100% outside air modulation. These control settings provide different modulation ranges depending on the target cfm-per-person ventilation rate desired. As described below the exponential setting is best used in applications that have large volumes of air and people such as auditoriums, gyms and large conference areas.

Setting 8 is for use in occupational health and safety applications where users want to measure concentrations in relation to the 5000 ppm 8 hour exposure levels established by OSHA (Occupation Safety and Health Administration).

Setting 9 is intended for use in parking garages where CO2 can be used as an indicator of the presence of combustion fumes. As part of most types of combustion, CO2 is generated at a rate that is 50 times or more of other more harmful contaminants. This is particularly the case with the extensive use of catalytic converters that tend to remove most of the carbon monoxide from vehicle exhaust. The 700 ppm setting should maintain levels of other exhaust contaminants well below levels of concern.

Custom Settings

In addition to the 9 standard settings programmed into the 8000 series, users can also custom program the sensor for their own application. Outlined below is a brief description of each of the adjustable custom settings:

Setting No	Type of Equipment	Type of Output	Ventilation Rate (cfm/Person)	Analog Output	CO2 Control Range (ppm)	Optional Relay Setpoint (ppm)	Relay Hysteresis (ppm)
1	Interface w/Standard Building Control System	Proportional	Any	0-10V 4-20mA	0-2000	1000	50
2	Interface w/Standard Building Control System	Proportional	Any	2-10V, 7-20 mA	0-2000	1000	50
3	Interface w/Standard Building Control System	Exponential	Any	0-10V 4-20mA	0-2000	1100	50
4	Economizer (Hvac)	Proportional	15	0-10V 4-20mA	0-1100	1100	50
5	Economizer (Hvac)	Proportional	20	0-10V 4-20mA	0-900	900	50
6	Economizer (Hvac)	Exponential	15	0-10V 4-20mA	0-1100	1100	50
7	Economizer (Hvac)	Exponential	20	0-10V 4-20mA	0-900	900	50
8	Health & Safety	Proportional	NA	0-10V 4-20mA	0-9999	5000	500
9	Parking/Air Intakes/Loading Docks	Proportional	NA	0-10V 4-20mA	0-2000	700	50

Standard Settings Adjustable via keypad or UIP Interface

- **Control Range:** The range that will correspond to the analog signal output range. The range consists of a low level and a high level in ppm. Setting this range does not limit the actual measurement or display range.
- **Analog Output Range:** Can be expressed in V or mA. This range will correspond to the range of CO2 concentrations established in the measurement range. A V and mA output is selected based on the wiring terminals. It is possible to simultaneously connect to both the V and mA outputs.
- **Proportional or Exponential Control:** Proportional (linear) control increases the signal output in proportion to the increase in CO2 concentrations for the measurement range and analog output range selected. Exponential control provides an output function that is exponential over the selected range of the sensor. The effect of the exponential output is to initially introduce more ventilation to the space as concentrations are at the lower level of the control range. The exponential output is particularly useful for areas of potential high occupancy and high air volume where significant time may be required for CO2 levels to build up. Potential applications include arenas, gyms, auditoriums and large conference areas. Examples of both types of outputs are provided below.

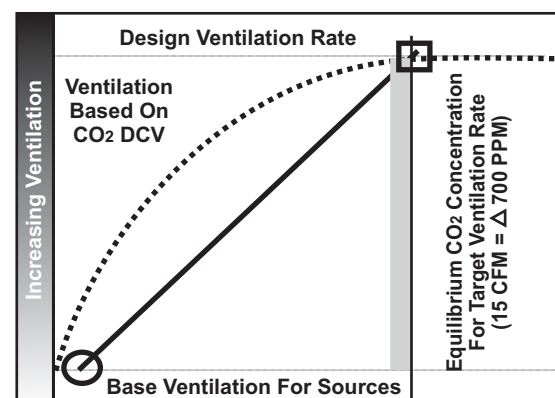

- **Minimum Position = Vs**
- **Maximum Position = Vs+Vp**
- **Relay Control Approach**
- **Deadband Setting Setpoint**

- **Relay Set Point:** Establishes the level at which the on-board relay will activate. The relay is a double pole single throw (DPST) relay that allows the user to operate the relay normally open or normally closed based on the selection of wiring terminals connected on the sub-base.
- **Relay Hysteresis (Deadband):** Is the point at which the relay will deactivate. It is entered as a ppm value below the setpoint. A sensor with a relay setting of 1000 and a hysteresis of 50 would activate at 1000 ppm and deactivate at 950 ppm.

Adjusting Sensor Using Display

Button Functions:

- [CLEAR] - Resets Menu / Returns to Normal Mode
- [MODE] - Toggles to Next Menu Item
- [ENTER] - Press to Lock Menu
- [UP/DOWN] - Increase/Decrease Selection Value

Altitude Correction and ABC Logic™ (On/Off):

1. After 2 minute warm-up period, press CLEAR + MODE. Hold at least 5 seconds until the sensor enters the edit mode.
 2. The first menu is Altitude correction. Use the UP/DOWN Rocker Button to adjust to the proper altitude in 500 ft. increments.
 3. Press ENTER to lock in value then press MODE to proceed to ABC Logic.
 4. Use the UP/DOWN Button to switch to ON or OFF.
 5. Press ENTER to lock value then press MODE to proceed to Normal Mode.
- It is recommended that ABC Logic is left ON for the best sensor operation.

Selecting a Pre-Programmed Setting:

The pre-programmed settings shown in the "Standard Settings" Table are factory set and cannot be changed. These settings can be selected from the Standard Settings (STDSET) menu. The Altitude and ABC Logic™ features can be changed without entering the Standard Settings (STDSET) menu.

1. After 2 minute warm-up period, press CLEAR + MODE and hold (at least 5 seconds) until the sensor enters the edit mode.
2. Press MODE 2 times. You will enter the STDSET menu.
3. Use the UP/DOWN button to select the desired pre-programmed number. Refer to "8. Configuring the Sensor" for the appropriate setting number.
4. Press ENTER to lock selection, press MODE to return to Normal Mode.

For Non-Standard (Custom) Settings:

The non-standard (custom) settings can be changed at any time after the sensor is powered up. The 7 variables are: PPM Range, Scale (proportional or exponential), Output (V or mA), Output Range V, Output Range mA, Relay Setpoint, and Relay Hysteresis. The Altitude and ABC Logic™ features can be changed without entering into the Non-Standard (NONSTD) menu.

1. After 2 minute warm-up period, press CLEAR + MODE and hold (at least 5 seconds) until the sensor enters the edit mode.
2. Press MODE 2 times. You will enter the STDSET menu.
3. Use the UP/DOWN Rocker Button to toggle to the NONSTD menu.
4. Press MODE to move through the variables. Use the UP/DOWN button to toggle to desired setting.
5. Press ENTER to lock in the selection, press MODE for the next variable.

Adjusting the Sensor with the UIP Program

The UIP 8000 (Model 2072) is a Windows based interface program designed to work with Ventostat ventilation controllers. It allows quick, easy adjustments to the output, elevation, relay setpoint, hysteresis and can be used with calibration for calibration.

This program is ideal for units without display but can also be used with display. The UIP accessory package comes with the program and cables for connecting the sensor to a laptop computer equipped with a serial communications port.

Below is a screen capture of the easy-to-use program.

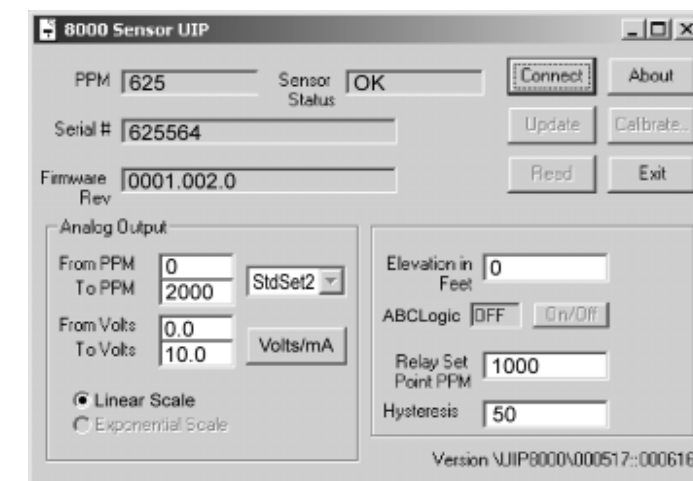

Screen Shot of Main UIP Screen